

EDSYN^{INC}®

971DF-230 LONER[®] SOLDERING STATION with fume extraction system

COMPLIES WITH DOD-STD-2000-1B MIL-STD-2000A and
ESD SPEC. DOD-STD 1868, DOD HDBK-263



Photo of US Model

instruction manual



971DF-230 LONER[®] SOLDERING STATION with fume extraction system

Contents at a Glance

Page 3 Features & Specifications

Page 4 Tip Care & Replacement

Page 5 Maintenance & Calibration

Page 6 - 7 Spare Parts List
& Trouble Shooting

Power Cords

For 971DF-230

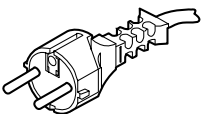

For 971DF-230B

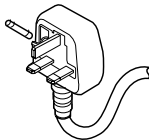

For 971DF-230I

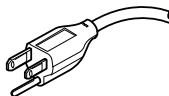

For 971DF-230P
POWER CORD WIRING

BROWN to LINE
BLUE to NEUTRAL
GRN/YEL to GROUND



FEATURES

- High vacuum output
- Automatic vacuum shut-off
- Modular assembly
- Easily converted to hot air soldering system
- Efficient & easy to clean filter system
- Check valve equipped high pressure hose

OPERATING REQUIREMENTS:

- 230 V, 50 Hz
- Shop air 60 - 90 psi (clean & dry)



Static Safe

SPECIFICATIONS

- 230V, 50Hz, 15W - 220W, 2.5 lbs. (1.1 kg.)
- COMPLIES WITH DOD-STD-2000-1B, MIL-STD-2000A and ESD SPEC. DOD-STD 1868, DOD-HDBK-263
- TEMP. RANGE: 400°F - 800°F (205°C - 427°C)
- TEMP. REGULATION: $\pm 6^\circ\text{F}$ ($\pm 3^\circ\text{C}$)
- TIP TO GROUND LEAKAGE: $< 2\text{MV}$
- TIP TO GROUND RESISTANCE: $< 2\text{ OHMS}$
- UL LISTED

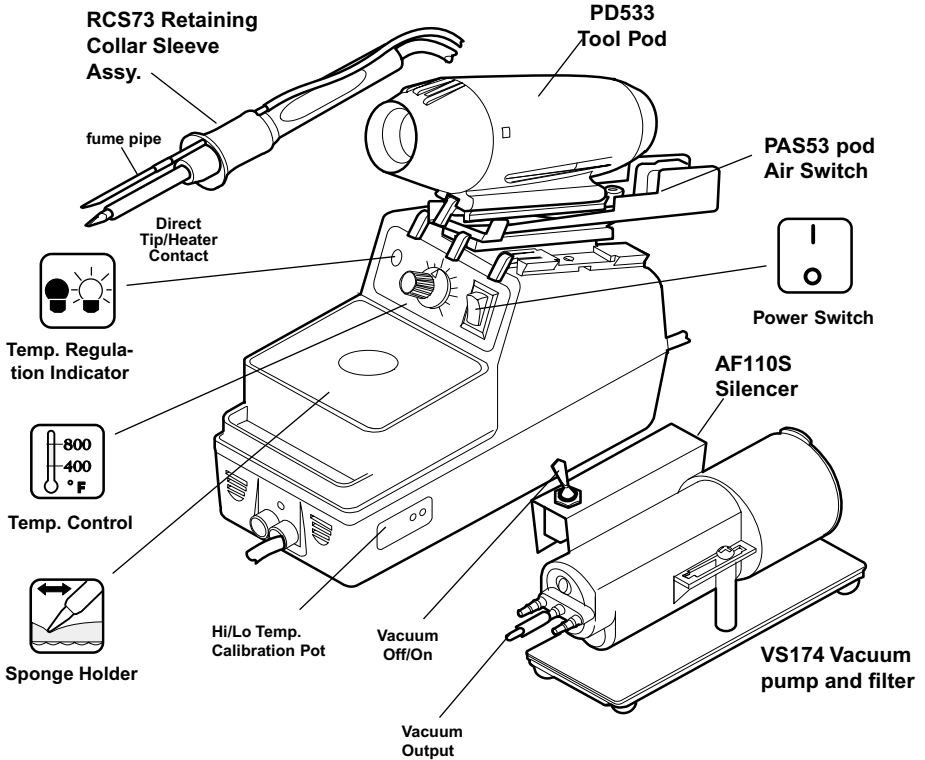

HOSE DIAGRAM

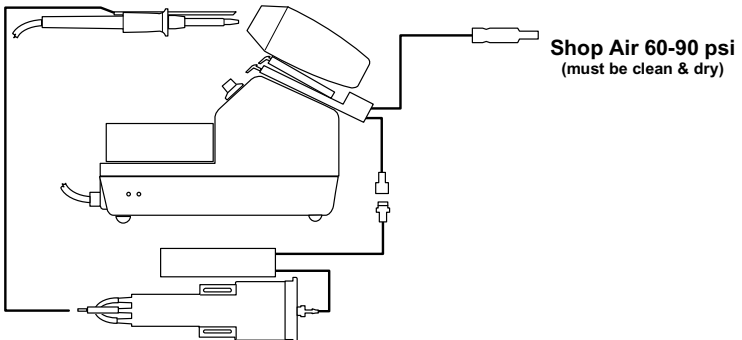

TIP CARE

1. Set desired temperature. Blinking Lamp means Tool is regulating.
2. TIN the Tip. (apply solder)
3. Do not rub, bend or reshape the Tip.
4. Always clean the Tip by wiping it against the saturated sponge and always RE-TIN.

WARNING: DO NOT HIT OR TAP THE TOOL. HEATER ELEMENT WILL BREAK!!!

REPLACING TIPS

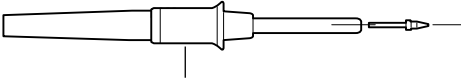

Loosen RCS73 Collar by turning counter-clockwise and pull the Tip straight out.

AFTER TIP IS INSTALLED, TIGHTEN COLLAR PROPERLY.

CAUTION

- Tool must be cool when changing tips.
- Do not twist or wiggle the tip.

General Purpose Soldering Tips

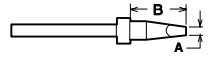

Iron Plated for long life•Nickel and Chrome Plated for optimum heat transfer.

EDSYN has over a 100 varieties of standard and custom-made Tips. CONTACT EDSYN FOR MORE SELECTIONS.

	Part No. & Description	a	b
	LT374 Standard Probe	.03 (0.8 mm)	.48 (12.2 mm)
	LT375 Standard Spade	.06 (1.5 mm)	.48 (12.2 mm)
	LT376-7 SMD Channel	.12 (3.0 mm)	.48 (12.2 mm)
	LT392 Extra-Long Needle	.02 (0.5 mm)	1.13 (28.8 mm)
	LT394 Extra-Long Spade	.07 (2.0 mm)	.93 (23.6 mm)
	LT399 Large Face	.17 (4.3 mm)	.49 (12.4 mm)
	LT444 SMD Mid-Length Fine Spade	.04 (1.0 mm)	.78 (19.8 mm)
	LT446 SMD Probe	.03 (0.8 mm)	.48 (12.2 mm)
	LT382 Long Cone	.02 (0.5 mm)	.62 (15.6 mm)
	LT395 Mid-Length Stubby Spade	.09 (2.3 mm)	.74 (18.8 mm)
	LT431 Mid-Length Spade	.07 (1.8 mm)	.74 (18.8 mm)
	LT439 SMD Thin Probe	.03 (0.8 mm)	.50 (12.7 mm)
	LT439-1 Same as LT439, Angled		
	LT445 SMD Angle Face	.03 (0.8 mm)	.48 (12.2 mm)

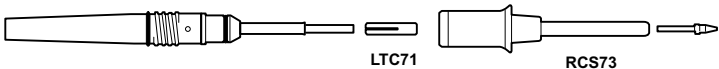

LTC71

RCS73

RCS73 Retaining Collar Sleeve

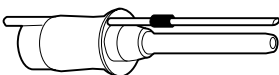

Adjust the length of the fume pipe according to tip length

OPTIONS

The 971DF can be converted to a Hot Air soldering system. Ask for PR570 Air Flow Regulator, RCS75 Retaining Collar Sleeve, LTA75H Insert Accumulator and LT428 Hot Air Tip.

PAS53 Pod Air Switch

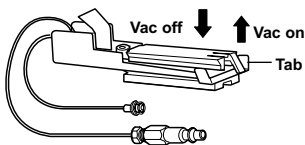

With tool out of the pod,
push in Tab to lock:
Vacuum on (continuous)

With tool in the pod,
push in Tab to lock:
Vacuum off (disable)

MAINTENANCE

• Replace RS199 Cleaning Sponge

1. Fill water only up to the top of the RS243 Leveling Pad.
2. Depress RS199 to moisten it completely.

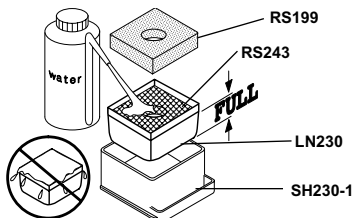

CAUTION:
Over-filling can cause thermal shock to the tip
or heating element during tip cleaning.

• Replace SC581 Solder Collector

1. Hold the Housing firm and turn Cap counter-clockwise and pull it away from the Housing.
2. Remove used SC581 and replace with a new one.
3. Reassemble Pod with TOP of the Cap in proper position.

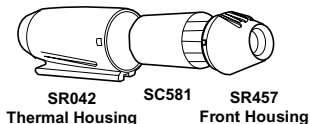

• Replace VS174 Filters

1. Pull cap from housing.
2. Replace filters as shown.
3. Replace O-ring if worn out.

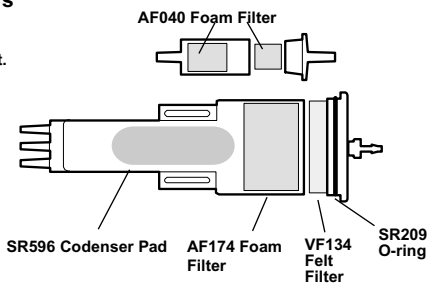

TEMPERATURE CALIBRATION

AIR MOVEMENT WILL AFFECT THE TEMPERATURE READING. WORK IN AN AREA WHERE THIS IS MINIMAL.

1. Turn on power and set Temperature Control Knob to 400°F.
2. Using a clean and well tinned Tip, apply a small amount of solder on the Tip, just enough to form a bead on top of the Tip.
3. Place the center of the thermocouple wire of the SDS100 on top of the bead.
4. Again, apply a small amount of solder on the center of the thermo-couple wire, just enough to embed the center.
5. Adjust LO-Temp. Calibration Pot so the Meter will read 400°F.
6. Set Temperature Control Knob to 800°F.
7. Adjust Hi-Temp. Calibration Pot so the Meter will read 800°F.

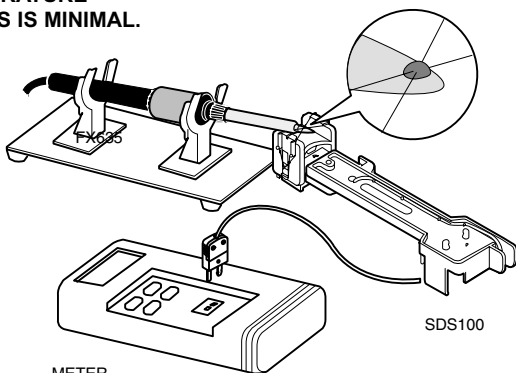

METER

MS412
Temperature
Calibration System

**971DF-230 LONER®
SOLDERING STATION
SPARE PARTS LIST**

ITEM NO.	PART NO.	DESCRIPTION	QTY REQ'D
2	SH230	General Purpose Sponge Holder	1
2A	RS199	Cleaning Sponge	1
2B	RS243	Leveling Pad for SH230	1
2C	LN230	Liner for SH230	1
2D	SH230-1	Sponge Holder Tray	1
3	SR365	Control Panel Label	1
4	SR452	Power Switch	1
5	SR045	Knob, Temperature Control	1
6	SR243	5K Potentiometer, Temperature Control	1
7	SR015	Flat Head Screw- Slotted #6 - 32 x 1/2	4
9	SR467	Hex Nut, Square Cone- #6 - 32	4
10	SR578	Top Base	1
11	SR019	Dove Tail Mount	1
12	15242W53	Circuit Board	1
13	SR573	LED Assy. Front Panel Mount	1
14	SR365	Bottom Base	1
15	SR011	Pan Head Screw- Phillip #6 - 18 x 5/8	4
16	SR387	Transformer, Dual Prim.	1
17		Power Cord Assy. SR547 for -230P SR548 for -230 SR549 for -230B SR580 for -230I	1
18	SR251	Rubber Foot	4
19	SR481	Connector Assy.	1
20	SR241	Strain Relief for Power Cord	1
21	SR543	Fuse, 250V, 1. A (5mm x 20 mm)	1
22	SR818	Soldering Tool, Complete Assembly	1
22A	SR579	Handle for Tool	1
22B	SR058	Tool Cord Strain Relief	1
22C	SR280	Tool Cord, Burn Proof (Connector Assy. on one end)	1
22D	SR607	Heater Assembly	1
22E	LTC71	Tip Collet	1
22F	RCS73	Retaining Collar and Sleeve for Fume Extraction	1
22G	LT375	LONER Standard Spade Tip	1
22H	SR001	O-Ring, Silicone, .30 ID	1
22I	SR240	O-Ring, For Handle, .50 ID	1
22J	SR525	Hose, Low Static, 1/4 I.D. (sold per ft)	5 1/4"
22L	HS307	Hose, Low Static Silicone, 1/8 I.D. (sold per ft.)	3 ft.
23	SR301	Plug, Covering for Strain Relief, Tool Cord Outlet	1
24	SR255	Spacer for Potentiometer	1
25	SR310	Label, Set Pot, Right Front or Left Rear	1
26	PAS53	Pod Air Switch	1
27	VS174	Vacuum and Filter System	1

971DF-230 instruction manual

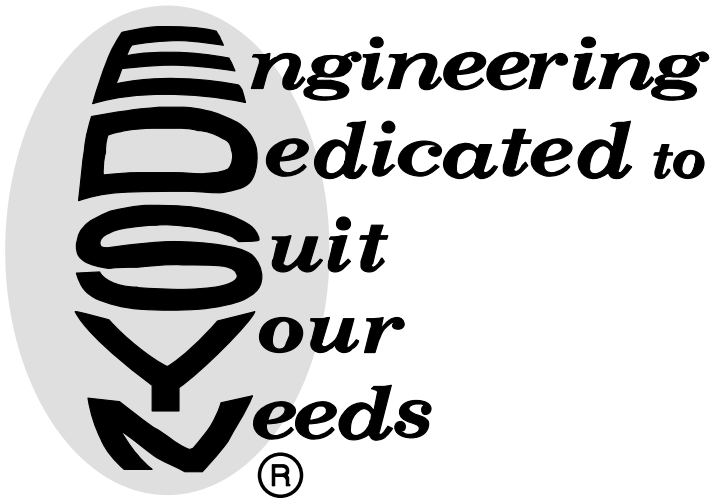

ALL RIGHTS RESERVED.

NO PART OF THIS PUBLICATION INCLUDING THE INDIVIDUAL ICONS
MAY BE REPRODUCED OR UTILIZED IN ANY FORM OR BY ANY MEANS
WITHOUT THE PERMISSION OF EDSYN, INC.

THE NAMES LONER, SOLDAPULLT, SOLDAVAC, ATMOSCOPE
AUTO-VAC, IDLE-REST, OCTAVAC, PIXER, FUMINATOR AND KLATCH
ARE REGISTERED TRADEMARKS OF EDSYN, INC.

MOST PRODUCTS ARE COVERED BY U.S. AND
FOREIGN PATENTS AND PENDING APPLICATIONS.



Intellectual
Property

DESIGN, COLOR AND MATERIALS
SUBJECT TO CHANGE WITHOUT NOTICE.

TIP STYLE ON SOLDERING, DESOLDERING AND HOT AIR TOOLS MAY VARY.

PRINTED IN U.S.A.



EDSYN INC [®]

...the power of precision

15958 Arminta Street • Van Nuys • CA 91406-1896
Web Site www.edsyn.com • eMail info@edsyn.com